

VIPA System SLIO

PS-CM | | Manual

HB300 | PS-CM | | GB | 14-24

VIPA GmbH
Ohmstr. 4
91074 Herzogenaurach
Telephone: 09132-744-0
Fax: 09132-744-1864
email: info@vipa.com
Internet: www.vipa.com

Table of contents

1	General	4
1.1	Copyright © VIPA GmbH	4
1.2	About this manual.....	5
1.2.1	Safety information.....	6
2	Basics and Assembly	8
2.1	Safety information for users.....	8
2.2	System conception.....	9
2.3	Dimensions.....	12
2.4	Installation.....	13
2.5	Demounting and module exchange.....	18
2.6	Wiring.....	22
2.7	Trouble shooting - LEDs.....	26
2.8	Installation guidelines.....	26
2.9	General data.....	29
3	Power modules	31
3.1	Safety precautions.....	31
3.2	007-1AB00 - DC 24V 10A.....	31
3.2.1	Technical data.....	35
3.3	007-1AB10 - DC 24V 4A, DC 24V/5V 2A.....	36
3.3.1	Technical data.....	39
4	Clamp modules	41
4.1	001-1BA00 - 8xDC 24V clamps.....	41
4.1.1	Technical data.....	42
4.2	001-1BA10 - 8xDC 0V clamps.....	43
4.2.1	Technical data.....	44
4.3	001-1BA20 - 4xDC 24V and 4xDC 0V clamps.....	45
4.3.1	Technical data.....	46

1 General

1.1 Copyright © VIPA GmbH

All Rights Reserved

This document contains proprietary information of VIPA and is not to be disclosed or used except in accordance with applicable agreements.

This material is protected by the copyright laws. It may not be reproduced, distributed, or altered in any fashion by any entity (either internal or external to VIPA), except in accordance with applicable agreements, contracts or licensing, without the express written consent of VIPA and the business management owner of the material.

For permission to reproduce or distribute, please contact: VIPA, Gesellschaft für Visualisierung und Prozessautomatisierung mbH Ohmstraße 4, D-91074 Herzogenaurach, Germany

Tel.: +49 9132 744 -0

Fax.: +49 9132 744-1864

E-Mail: info@vipa.de

<http://www.vipa.com>



Every effort has been made to ensure that the information contained in this document was complete and accurate at the time of publishing. Nevertheless, the authors retain the right to modify the information.

This customer document describes all the hardware units and functions known at the present time. Descriptions may be included for units which are not present at the customer site. The exact scope of delivery is described in the respective purchase contract.

CE Conformity Declaration

Hereby, VIPA GmbH declares that the products and systems are in compliance with the essential requirements and other relevant provisions. Conformity is indicated by the CE marking affixed to the product.

Conformity Information

For more information regarding CE marking and Declaration of Conformity (DoC), please contact your local VIPA customer service organization.

Trademarks	<p>VIPA, SLIO, System 100V, System 200V, System 300V, System 300S, System 400V, System 500S and Commander Compact are registered trademarks of VIPA Gesellschaft für Visualisierung und Prozessautomatisierung mbH.</p> <p>SPEED7 is a registered trademark of profichip GmbH.</p> <p>SIMATIC, STEP, SINEC, TIA Portal, S7-300 and S7-400 are registered trademarks of Siemens AG.</p> <p>Microsoft and Windows are registered trademarks of Microsoft Inc., USA.</p> <p>Portable Document Format (PDF) and Postscript are registered trademarks of Adobe Systems, Inc.</p> <p>All other trademarks, logos and service or product marks specified herein are owned by their respective companies.</p>
Information product support	<p>Contact your local VIPA Customer Service Organization representative if you wish to report errors or questions regarding the contents of this document. If you are unable to locate a customer service centre, contact VIPA as follows:</p> <p>VIPA GmbH, Ohmstraße 4, 91074 Herzogenaurach, Germany Telefax: +49 9132 744-1204 EMail: documentation@vipa.de</p>
Technical support	<p>Contact your local VIPA Customer Service Organization representative if you encounter problems with the product or have questions regarding the product. If you are unable to locate a customer service centre, contact VIPA as follows:</p> <p>VIPA GmbH, Ohmstraße 4, 91074 Herzogenaurach, Germany Tel.: +49 9132 744-1150 (Hotline) EMail: support@vipa.de</p>
1.2 About this manual	
Target audience	The manual is targeted at users who have a background in automation technology.
Structure of the manual	The manual consists of chapters. Every chapter provides a self-contained description of a specific topic.
Guide to the document	The following guides are available in the manual: <ul style="list-style-type: none">■ An overall table of contents at the beginning of the manual■ References with page numbers
Availability	The manual is available in: <ul style="list-style-type: none">■ printed form, on paper■ in electronic form as PDF-file (Adobe Acrobat Reader)

Icons Headings

Important passages in the text are highlighted by following icons and headings:

**DANGER!**

Immediate or likely danger. Personal injury is possible.

**CAUTION!**

Damages to property is likely if these warnings are not heeded.



Supplementary information and useful tips.

1.2.1 Safety information**Applications conforming with specifications**

The system is constructed and produced for:

- communication and process control
- industrial applications
- operation within the environmental conditions specified in the technical data
- installation into a cubicle

**DANGER!**

This device is not certified for applications in

- in explosive environments (EX-zone)

Documentation

The manual must be available to all personnel in the

- project design department
- installation department
- commissioning
- operation

**CAUTION!**

The following conditions must be met before using or commissioning the components described in this manual:

- Hardware modifications to the process control system should only be carried out when the system has been disconnected from power!
- Installation and hardware modifications only by properly trained personnel.
- The national rules and regulations of the respective country must be satisfied (installation, safety, EMC ...)

Disposal

National rules and regulations apply to the disposal of the unit!

2 Basics and Assembly

2.1 Safety information for users

Handling of electrostatic sensitive modules

VIPA modules make use of highly integrated components in MOS-Technology. These components are extremely sensitive to over-voltages that can occur during electrostatic discharges. The following symbol is attached to modules that can be destroyed by electrostatic discharges.



The Symbol is located on the module, the module rack or on packing material and it indicates the presence of electrostatic sensitive equipment. It is possible that electrostatic sensitive equipment is destroyed by energies and voltages that are far less than the human threshold of perception. These voltages can occur where persons do not discharge themselves before handling electrostatic sensitive modules and they can damage components thereby, causing the module to become inoperable or unusable. Modules that have been damaged by electrostatic discharges can fail after a temperature change, mechanical shock or changes in the electrical load. Only the consequent implementation of protection devices and meticulous attention to the applicable rules and regulations for handling the respective equipment can prevent failures of electrostatic sensitive modules.

Shipping of modules

Modules must be shipped in the original packing material.

Measurements and alterations on electrostatic sensitive modules

When you are conducting measurements on electrostatic sensitive modules you should take the following precautions:

- Floating instruments must be discharged before use.
- Instruments must be grounded.

Modifying electrostatic sensitive modules you should only use soldering irons with grounded tips.



CAUTION!

Personnel and instruments should be grounded when working on electrostatic sensitive modules.

2.2 System conception

Overview

System SLIO is a modular automation system for assembly on a 35mm mounting rail. By means of the peripheral modules with 2, 4 or 8 channels this system may properly be adapted matching to your automation tasks. The wiring complexity is low, because the supply of the DC 24V power section is integrated to the backplane bus and defective modules may be replaced with standing wiring. By deployment of the power modules in contrasting colours within the system, further isolated areas may be defined for the DC 24V power section supply, respectively the electronic power supply may be extended with 2A.

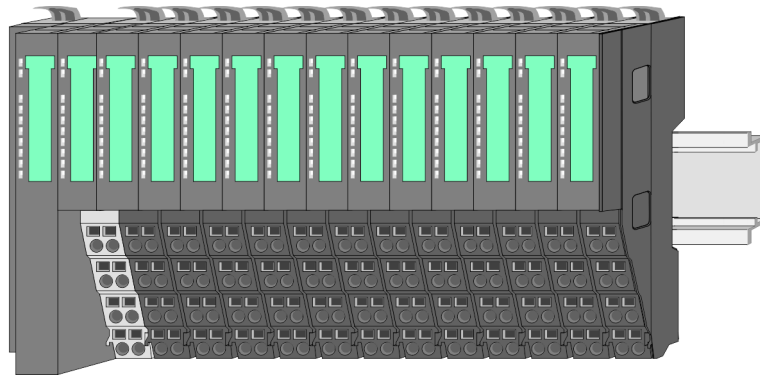

Components

- CPU (head module)
- Bus coupler (head module)
- Periphery modules
- Power modules
- Accessories



CAUTION!

Only modules of VIPA may be combined. A mixed operation with third-party modules is not allowed!

CPU



With a CPU, CPU electronic and power module are integrated to one casing. As head module via the integrated power module for power supply the CPU electronic is supplied as well as the electronic of the connected periphery modules. The DC 24 power section supply for the linked periphery modules is established via a further connection at the power module. By installing of up to 64 periphery modules at the CPU, these are electrically connected, this means these are assigned to the backplane bus, the electronic modules are power supplied and each periphery module is connected to the DC 24V power section supply.



CAUTION!

CPU part and power module of a CPU may not be separated! Here you may only exchange the electronic module!

Bus coupler

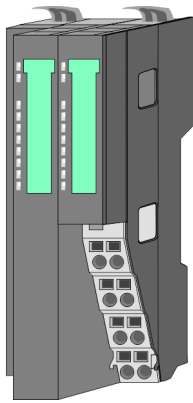

With a bus coupler bus interface and power module are integrated to one casing. With the bus interface you get access to a subordinated bus system. As head module via the integrated power module for power supply the bus interface is supplied as well as the electronic of the connected periphery modules. The DC 24 power section supply for the linked periphery modules is established via a further connection at the power module. By installing of up to 64 periphery modules at the bus coupler, these are electrically connected, this means these are assigned to the backplane bus, the electronic modules are power supplied and each periphery module is connected to the DC 24V power section supply.



CAUTION!

Bus interface and power module of the bus coupler may not be separated! Here you may only exchange the electronic module!

Periphery modules

Each periphery module consists of a *terminal* and an *electronic module*.

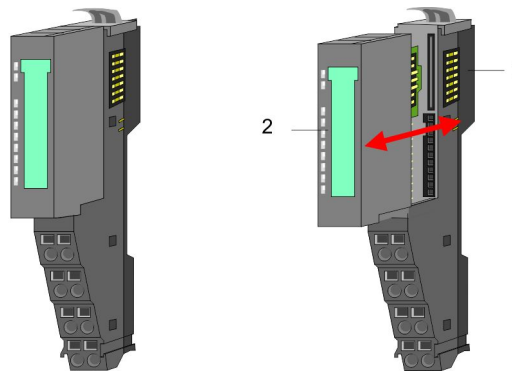

- 1 Terminal module
- 2 Electronic module

Terminal module

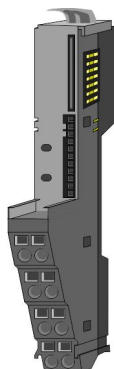

The *terminal module* serves to carry the electronic module, contains the backplane bus with power supply for the electronic, the DC 24V power section supply and the staircase-shaped terminal for wiring. Additionally the terminal module has a locking system for fixing at a mounting rail. By means of this locking system your SLIO system may be assembled outside of your switchgear cabinet to be later mounted there as whole system.

Electronic module

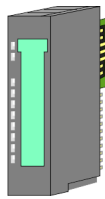

The functionality of a SLIO peripheral module is defined by the *electronic module*, which is mounted to the terminal module by a safe sliding mechanism. With an error the defective module may be exchanged for a functional module with standing installation.

At the front side there are LEDs for status indication. For simple wiring each module shows a corresponding connection diagram at the front and at the side.

Power module

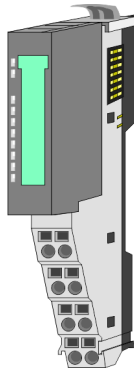

In the System SLIO the power supply is established by power modules. These are either integrated to the bus coupler or may be installed between the peripheral modules. Depending on the power module isolated areas of the DC 24V power section supply may be defined respectively the electronic power supply may be extended with 2A. For better recognition the colour of the power modules are contrasting to the periphery modules.

Accessories

Shield bus carrier

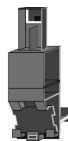

The shield bus carrier (order no. 000-0AB00) serves to carry the shield bus (10mm x 3mm) to connect cable shields. Shield bus carriers, shield bus and shield fixings are not in the scope of delivery. They are only available as accessories.

The shield bus carrier is mounted underneath the terminal of the terminal module. With a flat mounting rail for adaption to a flat mounting rail you may remove the spacer of the shield bus carrier.

Bus cover

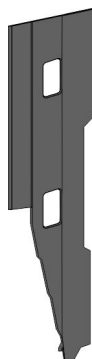

With each bus coupler, to protect the backplane bus connectors, there is a mounted bus cover in the scope of delivery. You have to remove the bus cover of the bus coupler before mounting a SLIO module. For the protection of the backplane bus connector you always have to mount the bus cover at the last module of your system again.

The bus cover has the order no. 000-0AA00.

Coding pins



There is the possibility to fix the assignment of electronic and terminal module. Here coding pins (order number 000-0AC00) from VIPA can be used.

The coding pin consists of a coding jack and a coding plug. By combining electronic and terminal module with coding pin, the coding jack remains in the electronic module and the coding plug in the terminal module.

This ensures that after replacing the electronics module just another electronic module can be plugged with the same encoding.

2.3 Dimensions

Dimensions CPU

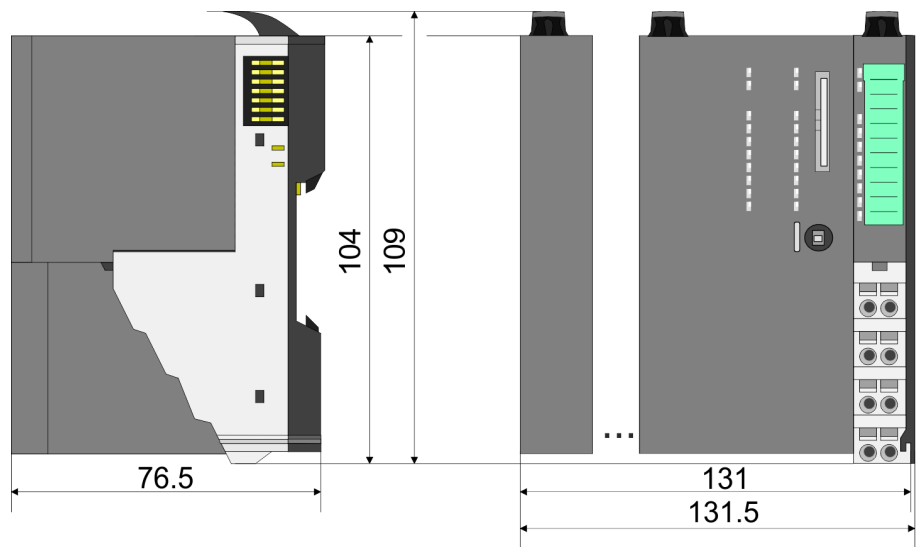

Dimensions bus coupler

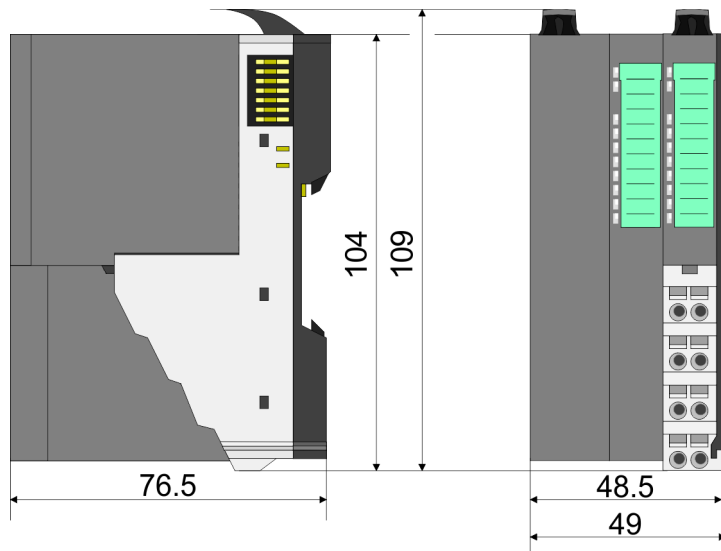

Dimensions periphery module

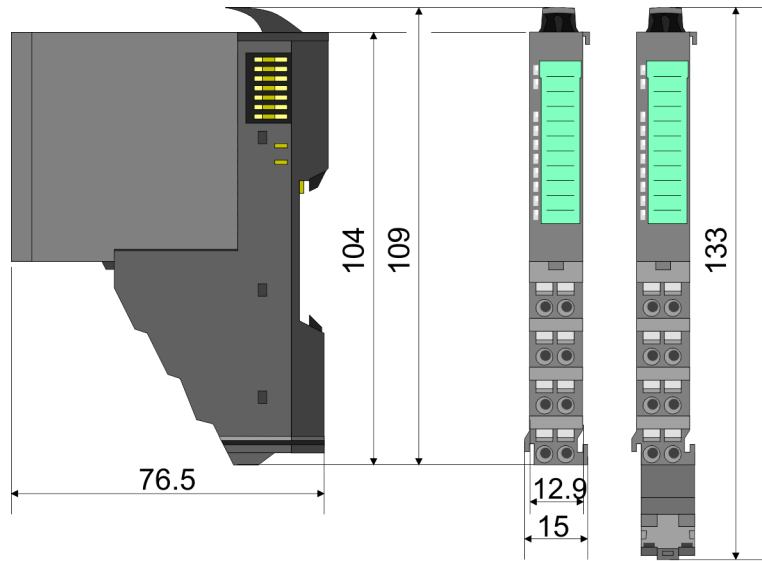

Dimensions electronic module

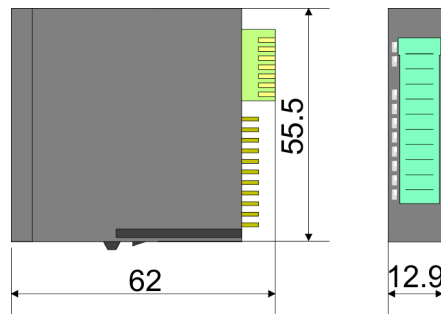

Dimensions in mm

2.4 Installation

Functional principle

There is a locking lever at the top side of the terminal module. For mounting and demounting this locking lever is to be turned upwards until this engages audible. Now the module may be pulled forward. For mounting plug the module to the module installed before and push the module to the mounting rail guided by the strips at the upper and lower side of the module. The module is fixed to the mounting rail by pushing downward the locking lever. The modules may either separately be mounted to the mounting rail or as block. Here is to be considered that each locking lever is opened.

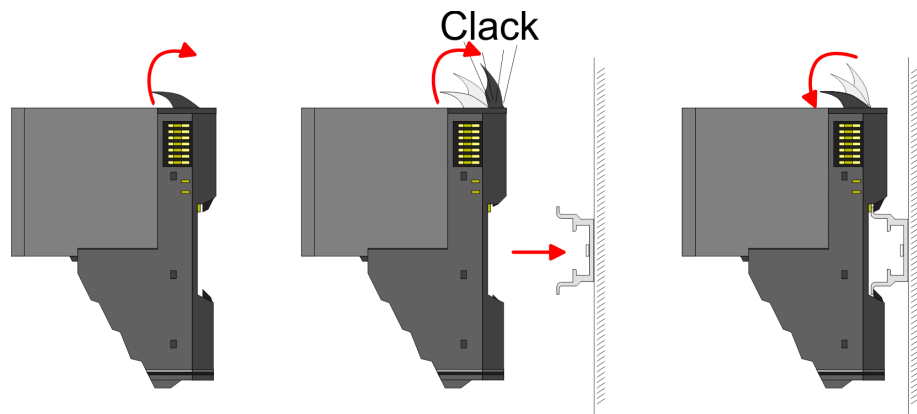

For the exchange of a electronic module, the electronic module may be pulled forward after pressing the unlocking lever at the lower side of the module. For installation plug the electronic module guided by the strips at the lower side until this engages audible to the terminal module.

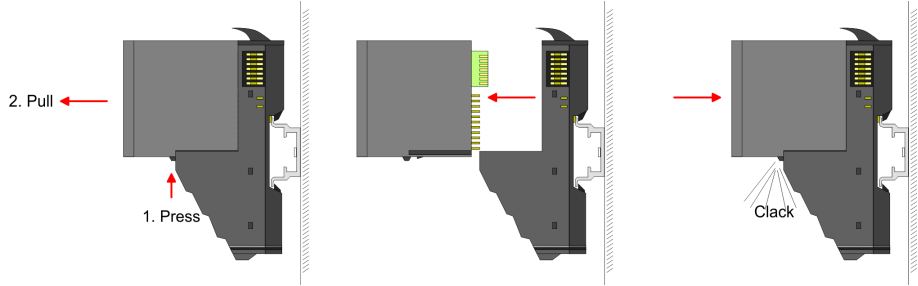

Coding



There is the possibility to fix the assignment of electronic and terminal module. Here coding pins (order number 000-0AC00) from VIPA can be used. The coding pin consists of a coding jack and a coding plug. By combining electronic and terminal module with coding pin, the coding jack remains in the electronic module and the coding plug in the terminal module. This ensures that after replacing the electronics module just another electronic module can be plugged with the same encoding.

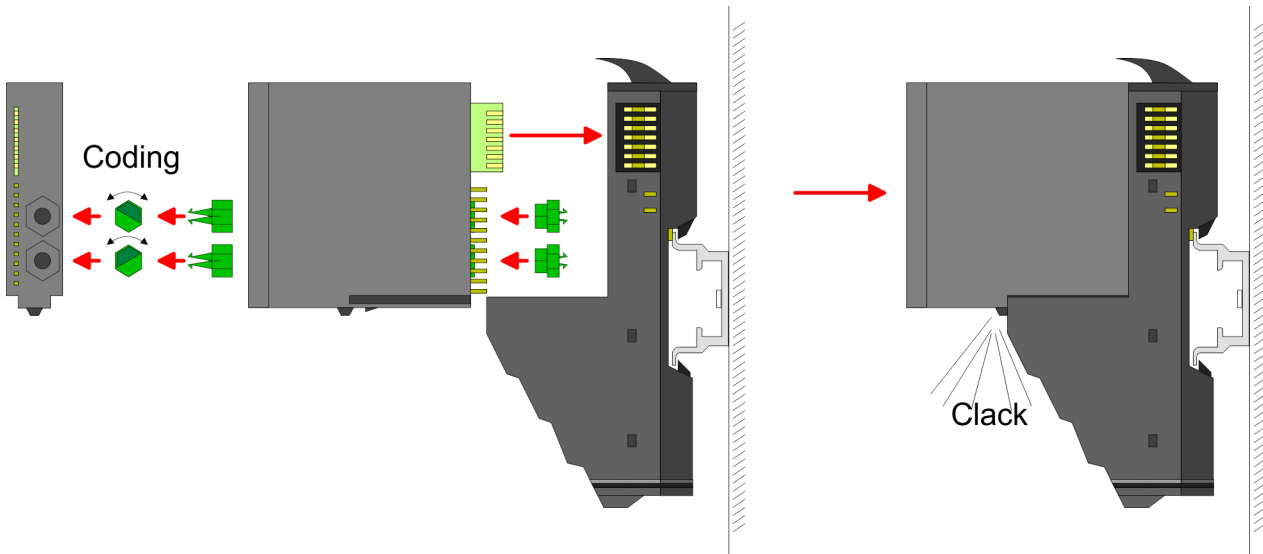

Each electronic module has on its back 2 coding sockets for coding jacks. Due to the characteristics, with the coding jack 6 different positions can be plugged, each. Thus there are 36 possible combinations for coding with the use of both coding sockets.

1. ► Plug, according to your coding, 2 coding jacks in the coding sockets of your electronic module until they lock.
2. ► Now plug the according coding plugs into the coding jacks.
3. ► To fix the coding put both the electronic and terminal module together until they lock.

 **CAUTION!** Please consider that when replacing an already coded electronic module, this is always be replaced by an electronic module with the same coding.

Even with an existing coding on the terminal module, you can plug an electronic coding module without coding. The user is responsible for the correct usage of the coding pins. VIPA assumes no liability for incorrectly attached electronic modules or for damages which arise due to incorrect coding!

Mounting Proceeding

The modules were directly be mounted to the mounting rail and so connected to the backplane bus and the power supply for the electronic and power section. Up to 64 modules may be mounted. Please consider here that the sum current of the electronic power supply does not exceed the maximum value of 3A. By means of the power module 007-1AB10 the current of the electronic power supply may be expanded with 2A. ↪ *Chapter 2.6 'Wiring' on page 22*

Mounting rail

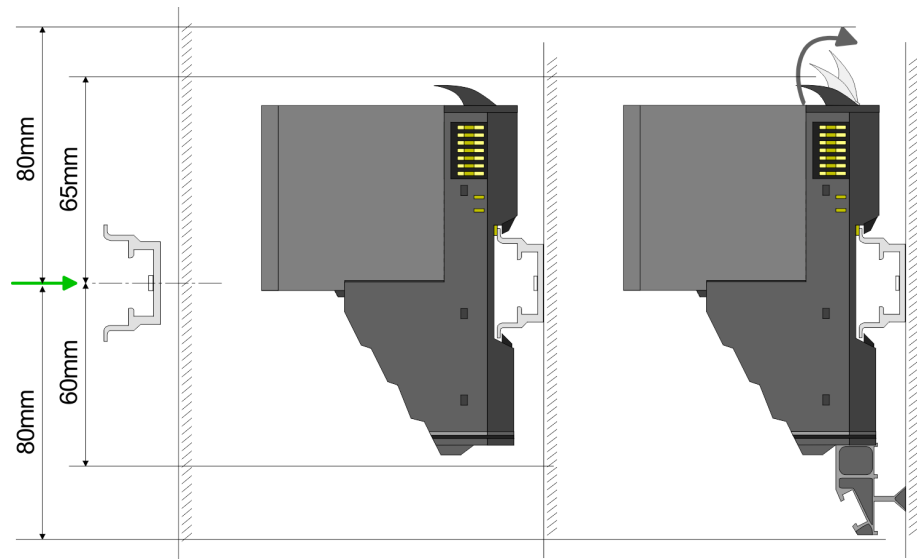

➔ Mount the mounting rail! Please consider that a clearance from the middle of the mounting rail of at least 80mm above and 60mm below, respectively 80mm by deployment of shield bus carriers, exist.

Mounting Head module (e.g. bus coupler)

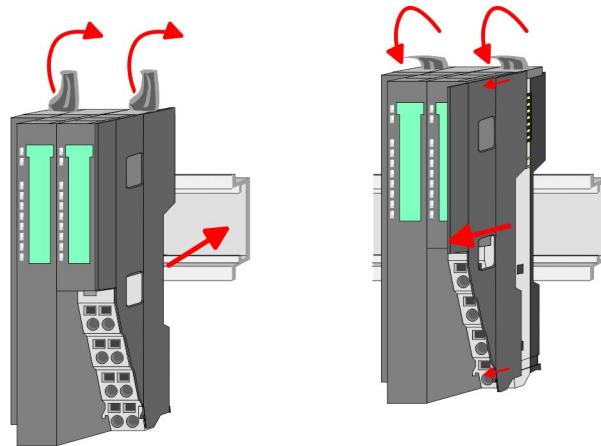

1. ▶ Start at the left side with the head module (e.g. bus coupler). For this turn both locking lever upwards, put the head module to the mounting rail and turn both locking lever downward.
2. ▶ Before mounting the periphery modules you have to remove the bus cover at the right side of the Head module by pulling it forward. Keep the cover for later mounting.

Mounting periphery modules

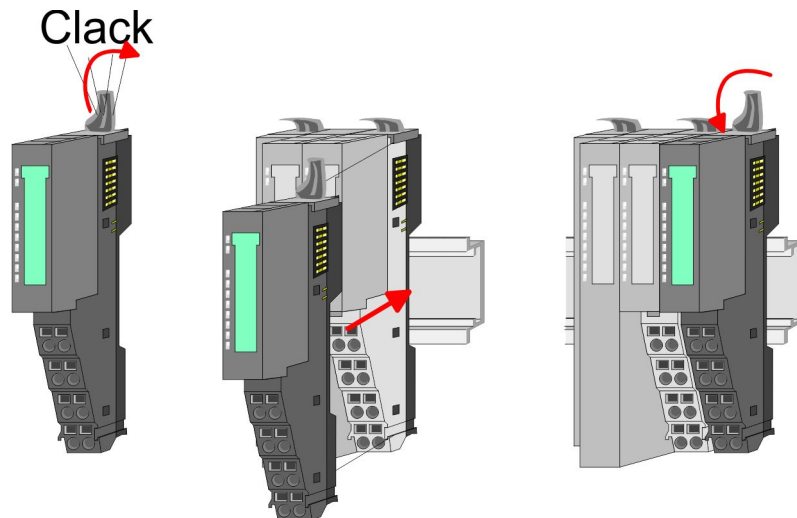

- ▶ Mount the periphery modules you want.

Mounting the bus cover

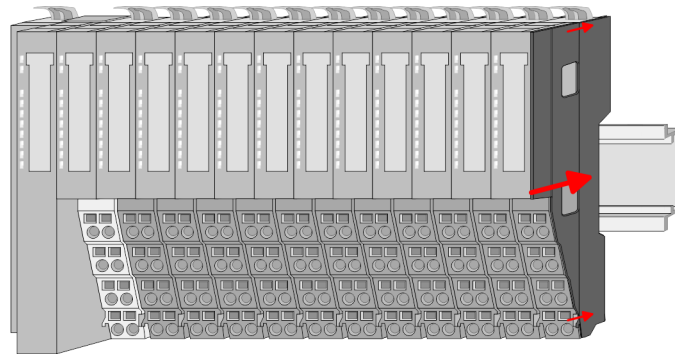

- ➔ After mounting the whole system, to protect the backplane bus connectors at the last module you have to mount the bus cover, now.

Mounting the bus cover at a clamp module

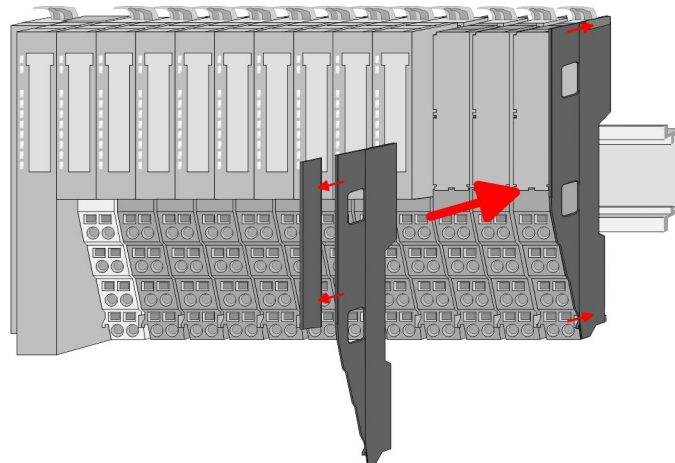

- ➔ If the last module is a clamp module, for adaptation the upper part of the bus cover is to be removed

Mounting shield bus carrier

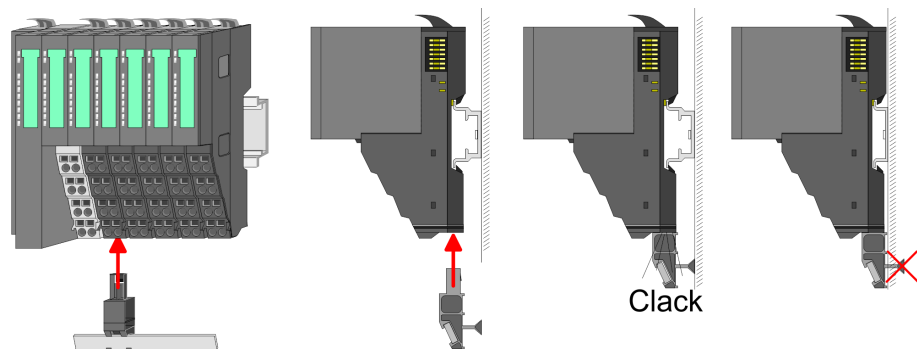

- ➔ The shield bus carrier (available as accessory) serves to carry the shield bus to connect cable shields. The shield bus carrier is mounted underneath the terminal of the terminal module. With a flat mounting rail for adaption to a flat mounting rail you may remove the spacer of the shield bus carrier.

2.5 Demounting and module exchange

Proceeding

With demounting and exchange of a module, head module (e.g. bus coupler) or a group of modules for mounting reasons you have always to remove the electronic module of the just mounted right module. After the mounting it may be plugged again.

Exchange of an electronic module

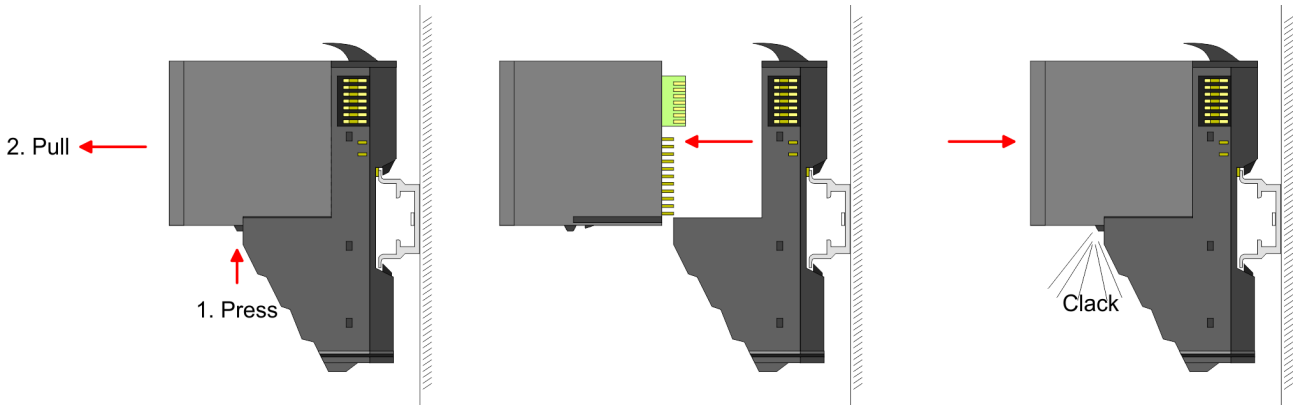

1. ➤ For the exchange of an electronic module, the electronic module may be pulled forward after pressing the unlocking lever at the lower side of the module.
2. ➤ For installation plug the electronic module guided by the strips at the lower side until this engages audible to the terminal module.

Exchange of a module

1. ➤ Remove if exists the wiring. ↪ *Chapter 2.6 'Wiring' on page 22.*

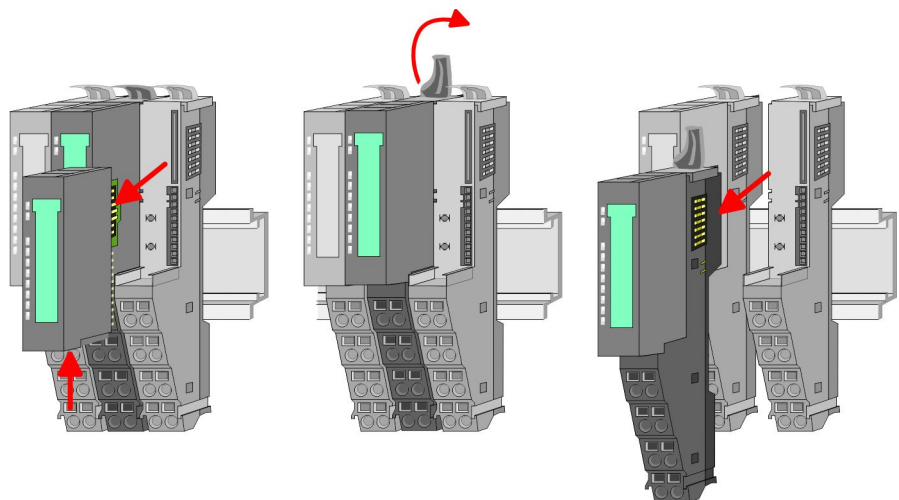

2. ➤ Press the unlocking lever at the lower side of the just mounted right module and pull it forward.
3. ➤ Turn the locking lever of the module to be exchanged upwards.
4. ➤ Pull the module forward.

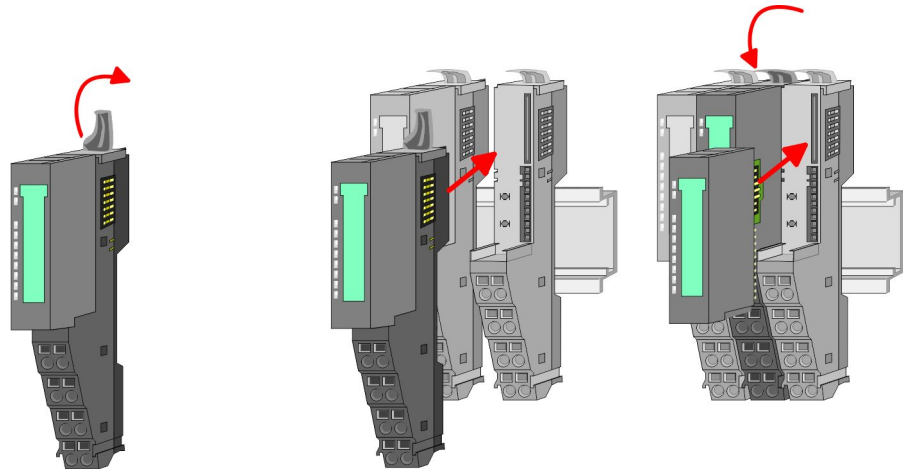

5. ▶ For mounting turn the locking lever of the module to be mounted upwards.
6. ▶ To mount the module put it to the gap between the both modules and push it, guided by the stripes at both sides, to the mounting rail.
7. ▶ Turn the locking lever downward again.
8. ▶ Plug again the electronic module, which you have removed before.

Exchange of a head module (e.g. bus coupler)



CAUTION!

Bus interface and power module of a head module may not be separated!

Here you may only exchange the electronic module!

1. ▶ Remove if exists the wiring of the head module. ↪ *Chapter 2.6 'Wiring' on page 22.*

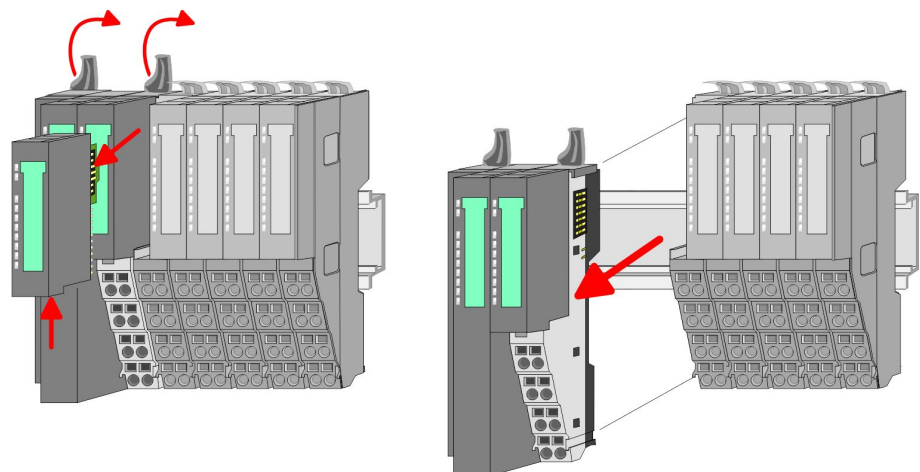

2. ▶ Press the unlocking lever at the lower side of the just mounted right module and pull it forward.
3. ▶ Turn all the locking lever of the head module to be exchanged upwards.
4. ▶ Pull the head module forward.

Demounting and module exchange

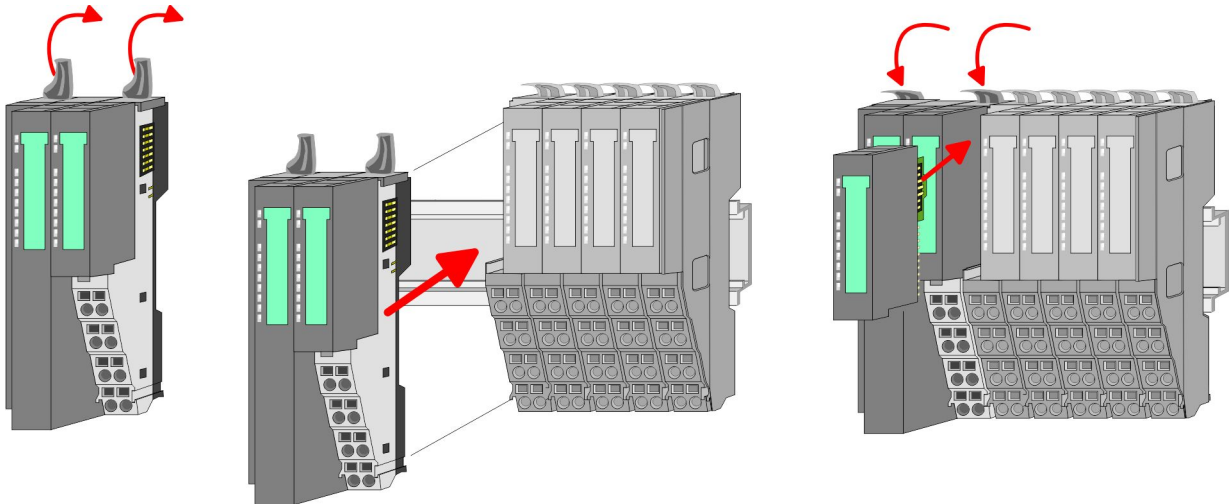

5. ▶ For mounting turn all the locking lever of the head module to be mounted upwards.
6. ▶ To mount the head module put it to the left module and push it, guided by the stripes, to the mounting rail.
7. ▶ Turn all the locking lever downward again.
8. ▶ Plug again the electronic module, which you have removed before.

Exchange of a module group

1. ▶ Remove if exists the wiring of the module group. ↪ *Chapter 2.6 'Wiring' on page 22.*

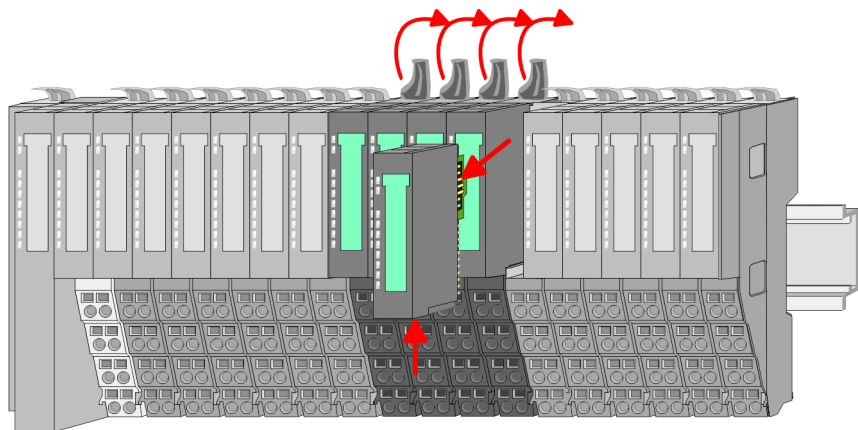

2. ▶ Press the unlocking lever at the lower side of the just mounted right module of the module group and pull it forward.

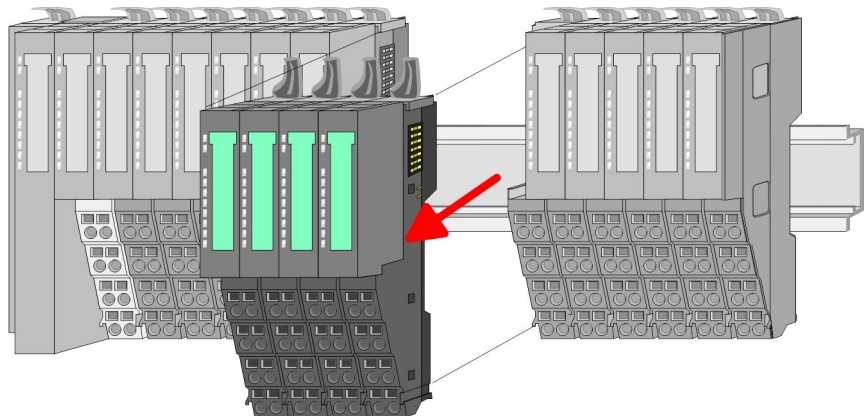

3. Turn all the locking lever of the module group to be exchanged upwards.
4. Pull the module group forward.

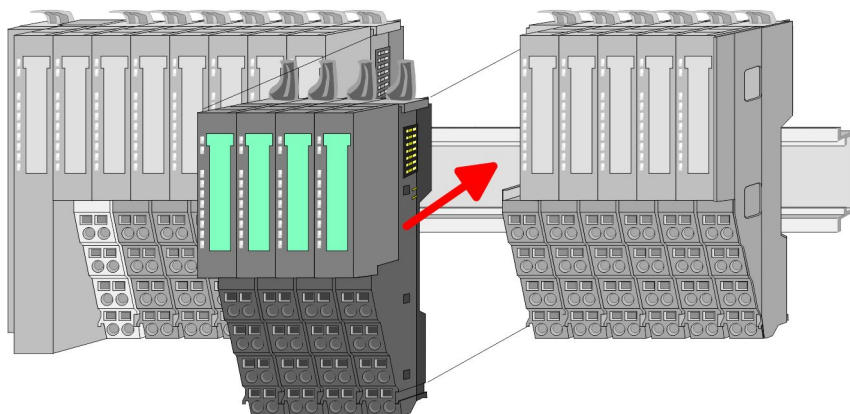
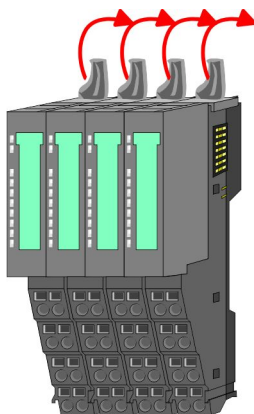

5. For mounting turn all the locking lever of the module group to be mounted upwards.
6. To mount the module group put it to the gap between the both modules and push it, guided by the stripes at both sides, to the mounting rail.

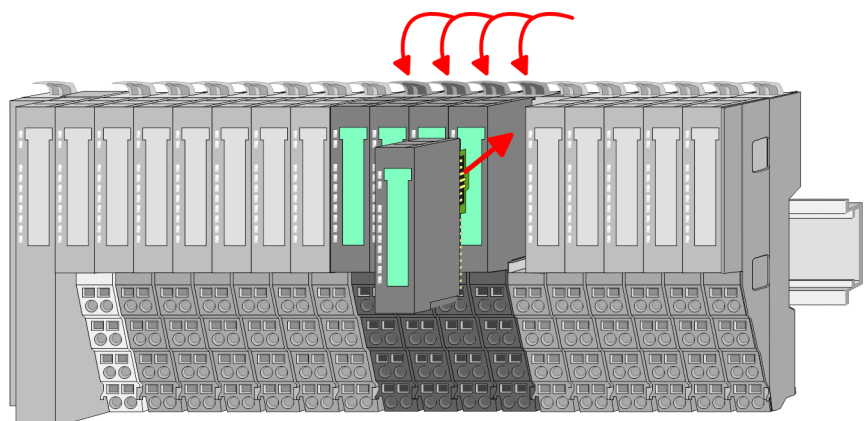

7. Turn all the locking lever downward again.
8. Plug again the electronic module, which you have removed before.

2.6 Wiring

Connectors

Terminals with spring clamp technology are used for wiring.

The spring clamp technology allows quick and easy connection of your signal and supply lines.

In contrast to screw terminal connections this type of connection is vibration proof.

Data

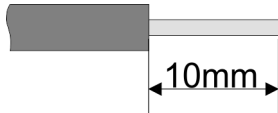

U_{max} : 240V AC / 30V DC

I_{max} : 10A

Cross section: 0.08 ... 1.5mm² (AWG 28 ... 16)

Stripping length: 10mm

Wiring procedure

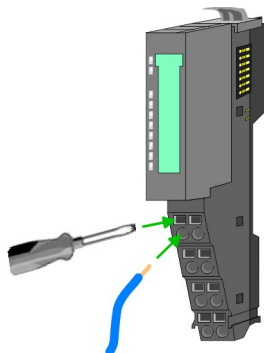
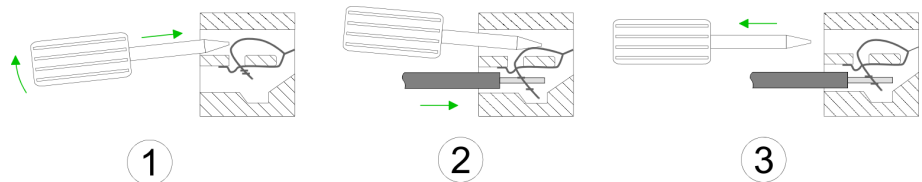

1. ➤ Insert a suited screwdriver at an angle into the square opening as shown. Press and hold the screwdriver in the opposite direction to open the contact spring.
2. ➤ Insert the stripped end of wire into the round opening. You can use wires with a cross section of 0.08mm² to 1.5mm².
3. ➤ By removing the screwdriver, the wire is securely fixed via the spring contact to the terminal.

Standard wiring

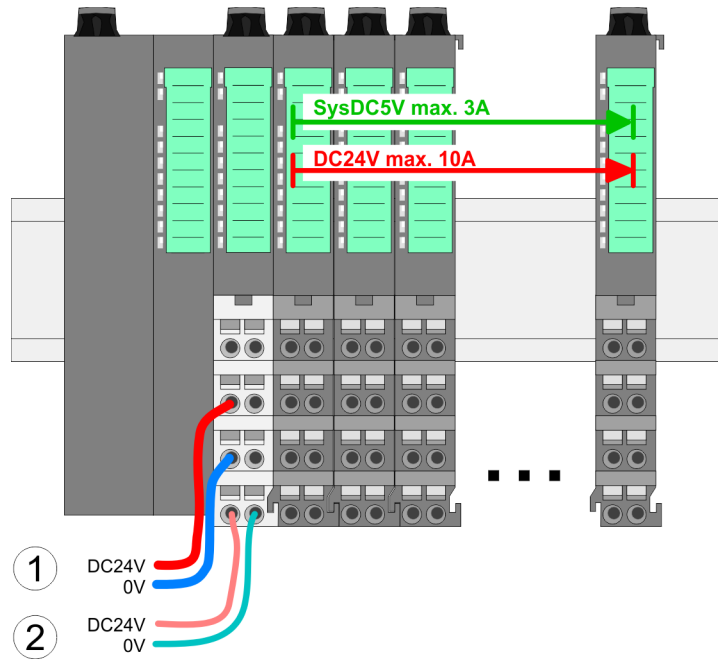

- (1) DC 24V for power section supply I/O area (max 10A)
- (2) DC 24V for electronic power supply bus coupler and I/O area

PM - Power module

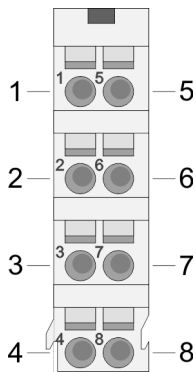

For wires with a core cross-section of 0.08mm² up to 1.5mm².

Pos.	Function	Type	Description
1	---	---	not connected
2	DC 24V	I	DC 24V for power section supply
3	0V	I	GND for power section supply
4	Sys DC 24V	I	DC 24V for electronic section supply
5	---	---	not connected
6	DC 24V	I	DC 24V for power section supply
7	0V	I	GND for power section supply
8	Sys 0V	I	GND for electronic section supply

I Input



CAUTION!

Since the power section supply is not internally protected, it is to be externally protected with a fuse, which corresponds to the maximum current. This means max. 10A is to be protected by a 10A fuse (fast) respectively by a line circuit breaker 10A characteristics Z!



The electronic power section supply is internally protected against higher voltage by fuse. The fuse is within the power module. If the fuse releases, its electronic module must be exchanged!

Fusing

- The power section supply is to be externally protected with a fuse, which corresponds to the maximum current. This means max. 10A is to be protected with a 10A fuse (fast) respectively by a line circuit breaker 10A characteristics Z!
- It is recommended to externally protect the electronic power supply for bus coupler and I/O area with a 2A fuse (fast) respectively by a line circuit breaker 2A characteristics Z.
- The electronic power supply for the I/O area of the power module 007-1AB10 should also be externally protected with a 1A fuse (fast) respectively by a line circuit breaker 1A characteristics Z.

State of the electronic power supply via LEDs

After PowerON of the System SLIO the LEDs RUN respectively MF get on so far as the sum current does not exceed 3A.

With a sum current greater than 3A the LEDs may not be activated.

Here the power module with the order number 007-1AB10 is to be placed between the peripheral modules.

Deployment of the power modules

If the 10A for the power section supply is no longer sufficient, you may use the power module from VIPA with the order number 007-1AB00. So you have also the possibility to define isolated groups.

The power module with the order number 007-1AB10 is to be used if the 3A for the electronic power supply at the backplane bus is no longer sufficient. Additionally you get an isolated group for the DC 24V power section supply with 4A.

By placing the power module 007-1AB10 at the following backplane bus modules may be placed with a sum current of max. 2A. Afterwards the power module 007-1AB10 is to be placed again. To secure the power supply, the power modules may be mixed used.

Power module 007-1AB00

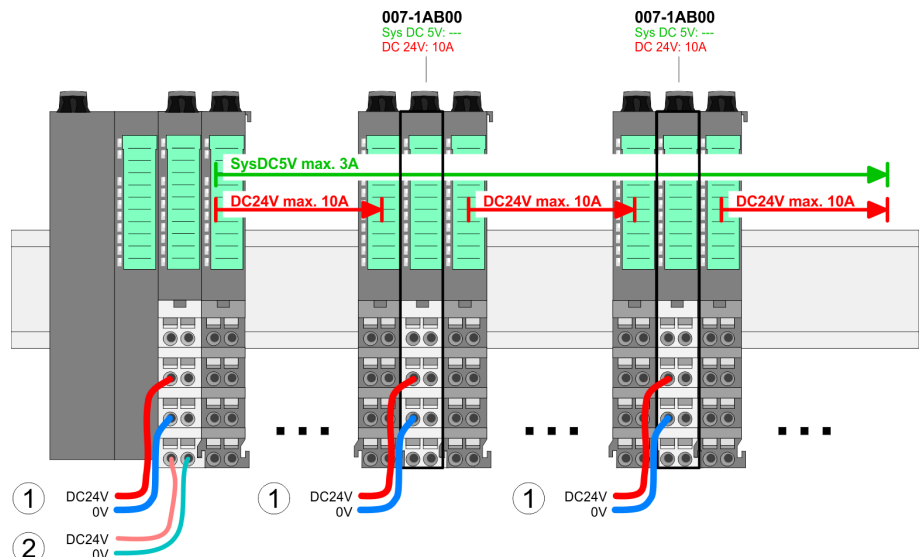

**Power module
007-1AB10**

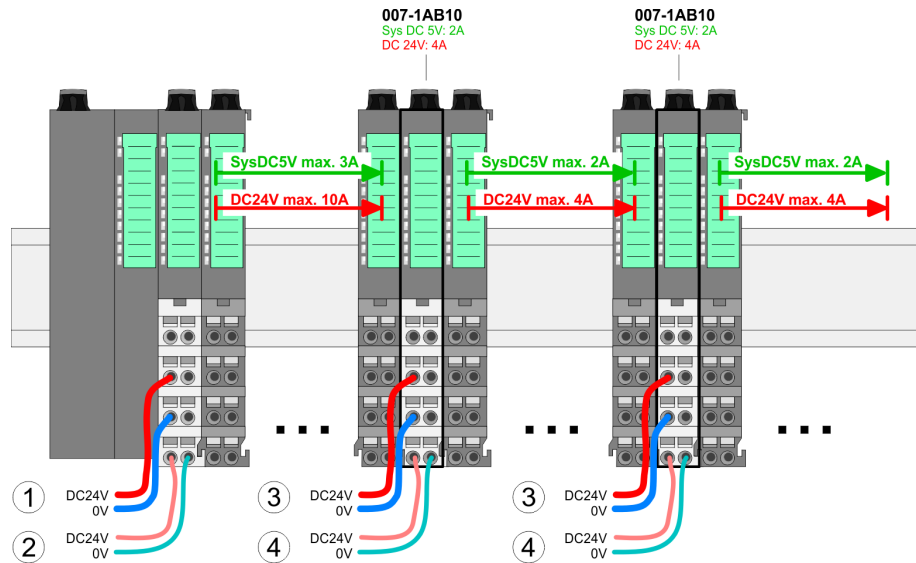

- (1) DC 24V for power section supply I/O area (max. 10A)
- (2) DC 24V for electronic power supply bus coupler and I/O area
- (3) DC 24V for power section supply I/O area (max. 4A)
- (4) DC 24V for electronic power supply I/O area

Shield attachment

To attach the shield the mounting of shield bus carriers are necessary.

The shield bus carrier (available as accessory) serves to carry the shield bus to connect cable shields.

The shield bus carrier is mounted underneath the terminal of the terminal module. With a flat mounting rail for adaption to a flat mounting rail you may remove the spacer of the shield bus carrier.

After mounting the shield bus carrier with the shield bus, the cables with the accordingly stripped cable screen may be attached and fixed by the shield clamp.

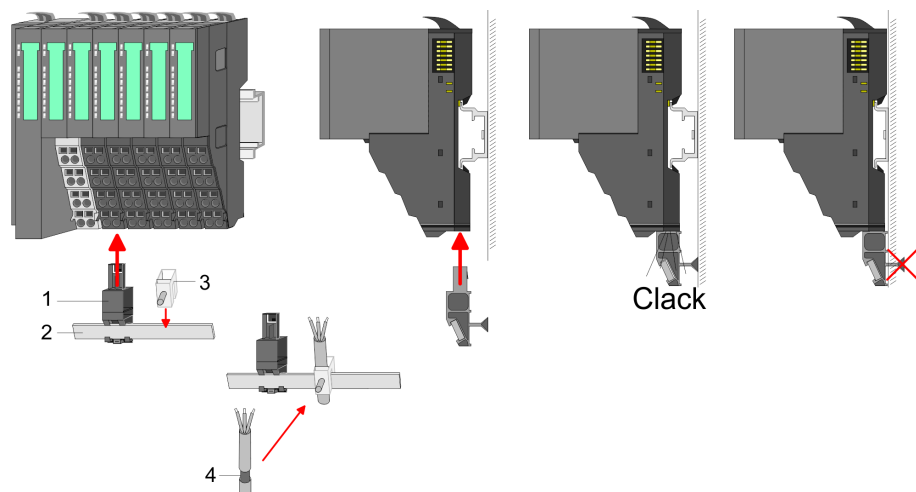

- 1 Shield bus carrier
- 2 Shield bus (10mm x 3mm)
- 3 Shield clamp
- 4 Cable shield

2.7 Trouble shooting - LEDs

General

Each module has the LEDs RUN and MF on its front side. Errors or incorrect modules may be located by means of these LEDs.

In the following illustrations flashing LEDs are marked by ☼.

Sum current of the electronic power supply exceeded

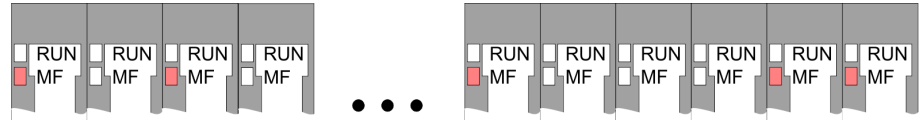

Behaviour: After PowerON the RUN LED of each module is off and the MF LED of each module is sporadically on.

Reason: The maximum current for the electronic power supply is exceeded.

Remedy: As soon as the sum current of the electronic power supply is exceeded, always place the power module 007-1AB10.

☞ Chapter 2.6 'Wiring' on page 22.

Error in configuration

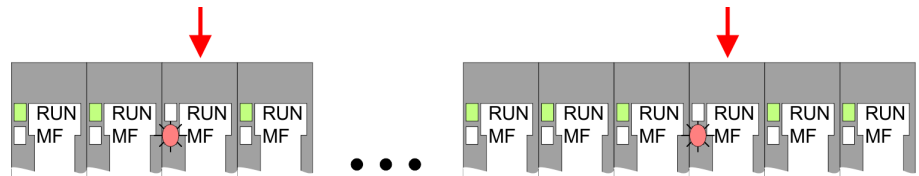

Behaviour: After PowerON the MF LED of one module respectively more modules flashes. The RUN LED remains off.

Reason: At this position a module is placed, which does not correspond to the configured module.

Remedy: Match configuration and hardware structure.

Module failure

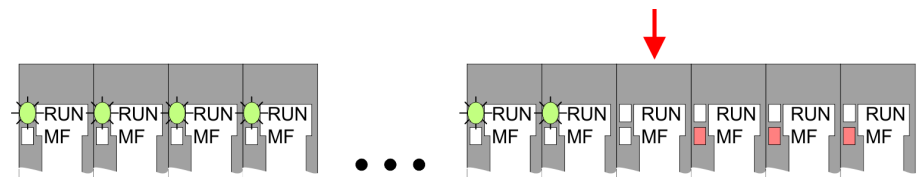

Behaviour: After PowerON all of the RUN LEDs up to the defective module are flashing. With all following modules the MF LED is on and the RUN LED is off.

Reason: The module on the right of the flashing modules is defective.

Remedy: Replace the defective module.

2.8 Installation guidelines

General

The installation guidelines contain information about the interference free deployment of a PLC system. There is the description of the ways, interference may occur in your PLC, how you can make sure the electromagnetic compatibility (EMC), and how you manage the isolation.

- What does EMC mean?** Electromagnetic compatibility (EMC) means the ability of an electrical device, to function error free in an electromagnetic environment without being interfered respectively without interfering the environment.
- The components of VIPA are developed for the deployment in industrial environments and meets high demands on the EMC. Nevertheless you should project an EMC planning before installing the components and take conceivable interference causes into account.
- Possible interference causes** Electromagnetic interferences may interfere your control via different ways:
- Electromagnetic fields (RF coupling)
 - Magnetic fields with power frequency
 - Bus system
 - Power supply
 - Protected earth conductor
- Depending on the spreading medium (lead bound or lead free) and the distance to the interference cause, interferences to your control occur by means of different coupling mechanisms.
- There are:
- galvanic coupling
 - capacitive coupling
 - inductive coupling
 - radiant coupling
- Basic rules for EMC** In the most times it is enough to take care of some elementary rules to guarantee the EMC. Please regard the following basic rules when installing your PLC.
- Take care of a correct area-wide grounding of the inactive metal parts when installing your components.
 - Install a central connection between the ground and the protected earth conductor system.
 - Connect all inactive metal extensive and impedance-low.
 - Please try not to use aluminium parts. Aluminium is easily oxidizing and is therefore less suitable for grounding.
 - When cabling, take care of the correct line routing.
 - Organize your cabling in line groups (high voltage, current supply, signal and data lines).
 - Always lay your high voltage lines and signal respectively data lines in separate channels or bundles.
 - Route the signal and data lines as near as possible beside ground areas (e.g. suspension bars, metal rails, tin cabinet).
 - Proof the correct fixing of the lead isolation.
 - Data lines must be laid isolated.
 - Analog lines must be laid isolated. When transmitting signals with small amplitudes the one sided laying of the isolation may be favourable.
 - Lay the line isolation extensively on an isolation/protected earth conductor rail directly after the cabinet entry and fix the isolation with cable clamps.
 - Make sure that the isolation/protected earth conductor rail is connected impedance-low with the cabinet.
 - Use metallic or metallised plug cases for isolated data lines.

- In special use cases you should appoint special EMC actions.
 - Consider to wire all inductivities with erase links.
 - Please consider luminescent lamps can influence signal lines.
- Create a homogeneous reference potential and ground all electrical operating supplies when possible.
 - Please take care for the targeted employment of the grounding actions. The grounding of the PLC serves for protection and functionality activity.
 - Connect installation parts and cabinets with your PLC in star topology with the isolation/protected earth conductor system. So you avoid ground loops.
 - If there are potential differences between installation parts and cabinets, lay sufficiently dimensioned potential compensation lines.

Isolation of conductors

Electrical, magnetically and electromagnetic interference fields are weakened by means of an isolation, one talks of absorption. Via the isolation rail, that is connected conductive with the rack, interference currents are shunt via cable isolation to the ground. Here you have to make sure, that the connection to the protected earth conductor is impedance-low, because otherwise the interference currents may appear as interference cause.

When isolating cables you have to regard the following:

- If possible, use only cables with isolation tangle.
- The hiding power of the isolation should be higher than 80%.
- Normally you should always lay the isolation of cables on both sides. Only by means of the both-sided connection of the isolation you achieve high quality interference suppression in the higher frequency area. Only as exception you may also lay the isolation one-sided. Then you only achieve the absorption of the lower frequencies. A one-sided isolation connection may be convenient, if:
 - the conduction of a potential compensating line is not possible.
 - analog signals (some mV respectively μA) are transferred.
 - foil isolations (static isolations) are used.
- With data lines always use metallic or metallised plugs for serial couplings. Fix the isolation of the data line at the plug rack. Do not lay the isolation on the PIN 1 of the plug bar!
- At stationary operation it is convenient to strip the insulated cable interruption free and lay it on the isolation/protected earth conductor line.
- To fix the isolation tangles use cable clamps out of metal. The clamps must clasp the isolation extensively and have well contact.
- Lay the isolation on an isolation rail directly after the entry of the cable in the cabinet. Lead the isolation further on to your PLC and don't lay it on there again!



CAUTION!

Please regard at installation!

At potential differences between the grounding points, there may be a compensation current via the isolation connected at both sides.

Remedy: Potential compensation line

2.9 General data

Conformity and approval

Conformity		
CE	2006/95/EG	Low-voltage directive
	2004/108/EG	EMC directive
Approval		
UL	UL 508	Approval for USA and Canada
others		
RoHS	2011/65/EU	Product is lead-free; Restriction of the use of certain hazardous substances in electrical and electronic equipment

Protection of persons and device protection

Type of protection	-	IP20
Electrical isolation		
to the field bus	-	electrically isolated
to the process level	-	electrically isolated
Insulation resistance		-
Insulation voltage to reference earth		
Inputs / outputs	-	AC / DC 50V, test voltage AC 500V
Protective measures	-	against short circuit

Environmental conditions to EN 61131-2

Climatic		
Storage / transport	EN 60068-2-14	-25...+70°C
Operation		
Horizontal installation	EN 61131-2	0...+60°C
Vertical installation	EN 61131-2	0...+60°C
Air humidity	EN 60068-2-30	RH1 (without condensation, rel. humidity 10... 95%)
Pollution	EN 61131-2	Degree of pollution 2
Mechanical		
Oscillation	EN 60068-2-6	1g, 9Hz ... 150Hz
Shock	EN 60068-2-27	15g, 11ms

General data

Mounting conditions

Mounting place	-	In the control cabinet
Mounting position	-	Horizontal and vertical

EMC	Standard	Comment
Emitted interference	EN 61000-6-4	Class A (Industrial area)
Noise immunity zone B	EN 61000-6-2	Industrial area
	EN 61000-4-2	ESD 8kV at air discharge (degree of severity 3), 4kV at contact discharge (degree of severity 2)
	EN 61000-4-3	HF irradiation (casing) 80MHz ... 1000MHz, 10V/m, 80% AM (1kHz) 1.4GHz ... 2.0GHz, 3V/m, 80% AM (1kHz) 2GHz ... 2.7GHz, 1V/m, 80% AM (1kHz)
	EN 61000-4-6	HF conducted 150kHz ... 80MHz, 10V, 80% AM (1kHz)
	EN 61000-4-4	Burst, degree of severity 3
	EN 61000-4-5	Surge, installation class 3 *

*) Due to the high-energetic single pulses with Surge an appropriate external protective circuit with lightning protection elements like conductors for lightning and overvoltage is necessary.

3 Power modules

3.1 Safety precautions

Appropriate use

The Power modules were designed and constructed:

- to be installed on mounting rail along with System SLIO components
- for installation in a cabinet with sufficient ventilation
- for industrial applications

The following precautions apply to applications employing the System SLIO power supplies.



DANGER!

- The Power modules must be installed in protected environments that are only accessible to properly qualified maintenance staff!
- The Power modules are not certified for applications in explosive environments (EX-zone)!
- You have to disconnect the Power modules from the main power source before commencing installation or maintenance work, i.e. before you start to work on a power supply or the supply cable the main supply line must be disconnected (disconnect plugs, on permanent installations the respective fuse has to be turned off)!
- Only properly qualified electrical staff is allowed to install, connect and/or modify electrical equipment!
- To provide a sufficient level of ventilation and cooling to the power supply components whilst maintaining the compact construction it was not possible to protect the unit from incorrect handling and a proper level of fire protection. For this reason the required level of fire protection must be provided by the environment where the power supply is installed (e.g. installation in a switchboard that satisfies the fire protection rules and regulations)!
- Please adhere to the national rules and regulations of the location and/or country where the units are installed (installation, safety precautions, EMC ...).

3.2 007-1AB00 - DC 24V 10A

Properties

If the 10A for the power section supply of the I/O area is no longer sufficient, you may use the power module. So you have also the possibility to define isolated groups. The power module is externally to be supplied with DC 24V.

- 10A feed-in for DC 24V power section supply I/O area
- Overvoltage protection
- Polarity reversal protection

007-1AB00 - DC 24V 10A

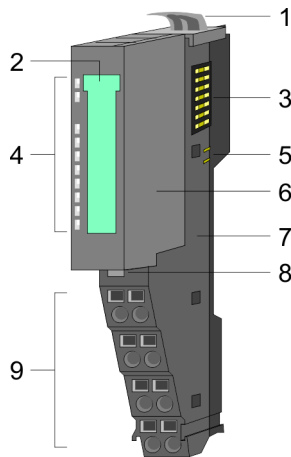

Structure

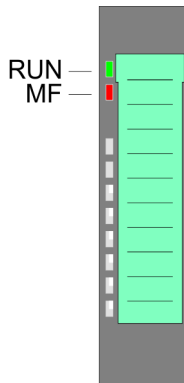

- 1 Locking lever terminal module
- 2 Labeling strip
- 3 Backplane bus
- 4 LED status indication
- 5 DC 24V power section supply
- 6 Electronic module
- 7 Terminal module
- 8 Locking lever electronic module
- 9 Terminal

Status display



RUN	MF *	Description
green	red	
		
●	○	DC 24V OK
●	●	Fuse defective
on: ● off: ○		
*) This LED is only available on the power module with hardware release 1. Information concerning the hardware release may be found underneath the label strip.		

Pin assignment

For wires with a cross section of 0.08mm² up to 1.5mm².

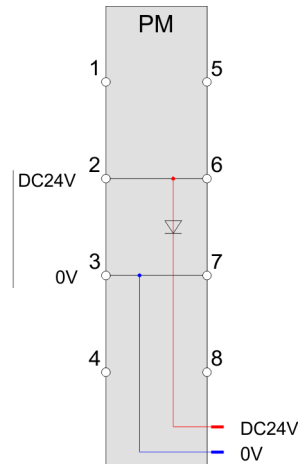
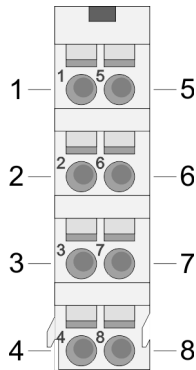

Pos.	Function	Type	Description
1	---	---	not connected
2	DC 24V	I	Feed-in DC 24V power section supply
3	0V	I	Feed-in ground GND power section supply
4	---	---	not connected
5	---	---	not connected
6	DC 24V	O	DC 24V power section supply I/Os
7	0V	O	ground GND power section supply I/Os
8	---	---	not connected

I: Input, O: Output



CAUTION!

Since the power section supply is not internally protected, it is to be externally protected with a fuse, which corresponds to the maximum current. This means max. 10A is to be protected by a 10A fuse (fast) respectively by a line circuit breaker 10A characteristics Z! Please consider within wiring the maximum load current of the contacts. With the System SLIO this is max. 10A.

Deployment

The following figure shows the standard cabling of the power supply by means of a bus coupler.

007-1AB00 - DC 24V 10A

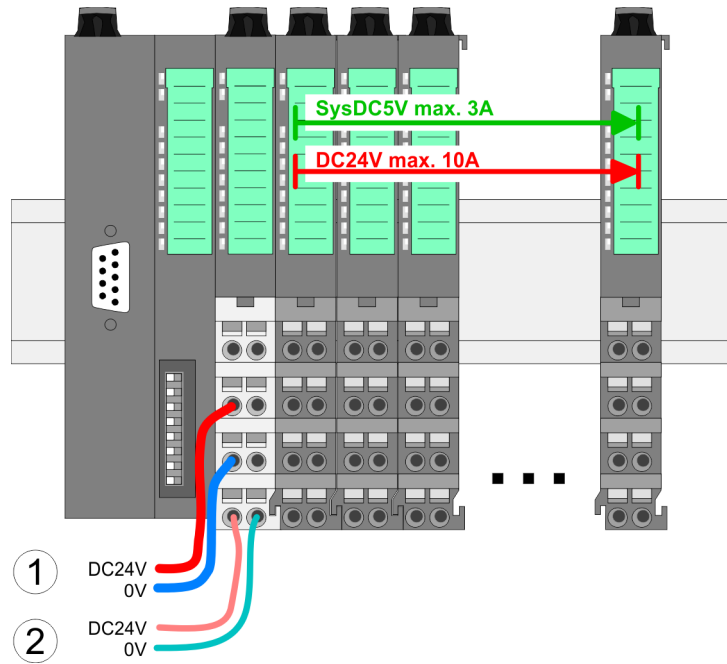

- 1 DC 24V for power section supply I/O area (max. 10A)
- 2 DC 24V for electronic power supply bus coupler and I/O area

Expansion by the power module 007-1AB00

As soon as the sum current of the power section supply exceeds 10A, the power module 007-1AB00 is to be placed. When the power module is placed, further modules may be placed besides the power module at the backplane bus, whose sum current of the power section supply does not exceed 10A. On this way the System SLIO may be expanded up to a maximum of 64 modules. Please consider that the sum current of the electronic power supply does not exceed the maximum of 3A. With a sum current greater than 3A the LEDs may not be activated. Here the power module with the order number 007-1AB10 is to be placed between the peripheral modules.

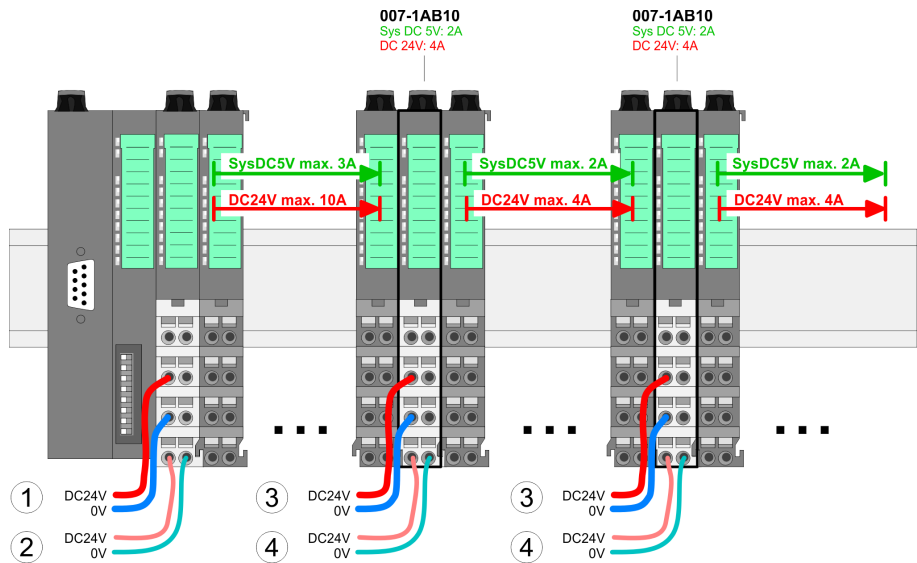

- 1 DC 24V for power section supply I/O area (max. 10A)
- 2 DC 24V for electronic power supply bus coupler and I/O area

3.2.1 Technical data

Order no.	007-1AB00
Type	PM 007
Module ID	-
Technical data power supply	
Input voltage (rated value)	DC 24 V
Input voltage (permitted range)	DC 20.4...28.8 V
Mains frequency (rated value)	-
Mains frequency (permitted range)	-
Input current (at 120 V)	-
Input current (at 230 V)	-
Inrush current	-
Power consumption	-
Output voltage (rated value)	24 V
Output current (rated value)	10 A
Power supply parallel switchable	-
Reverse polarity protection	yes
Overvoltage protection	36 V
Ripple of output voltage (max.)	-
Efficiency	-
Power loss	-
Status information, alarms, diagnostics	
Status display	yes
Interrupts	no
Process alarm	no
Diagnostic interrupt	no
Diagnostic functions	no
Diagnostics information read-out	none
Supply voltage display	green LED
Group error display	red LED
Channel error display	none
Housing	
Material	PPE / PPE GF10
Mounting	Profile rail 35 mm
Mechanical data	
Dimensions (WxHxD)	12.9 mm x 109 mm x 76.5 mm
Weight	60 g

007-1AB10 - DC 24V 4A, DC 24V/5V 2A

Order no.	007-1AB00
Environmental conditions	
Operating temperature	0 °C to 60 °C
Storage temperature	-25 °C to 70 °C
Certifications	
UL508 certification	yes

3.3 007-1AB10 - DC 24V 4A, DC 24V/5V 2A

Properties

If the 3A for the electronic power supply of the I/O area is no longer sufficient, you may use the power module. Additionally the power module serves for a new isolated group for the DC 24V power section supply with max. 4A. The power module is externally to be supplied with DC 24V.

- 2A feed-in for DC 24V electronic power supply I/O area
- 4A feed-in for DC 24V power section supply I/O area
- Overvoltage protection
- Polarity reversal protection

Structure

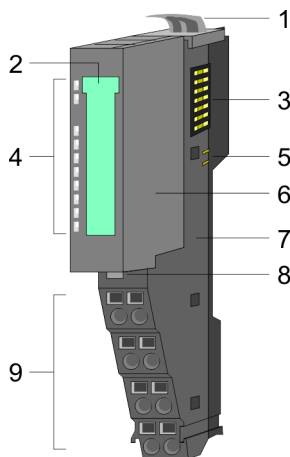

- 1 Locking lever terminal module
- 2 Labeling strip
- 3 Backplane bus
- 4 LED status indication
- 5 DC 24V power section supply
- 6 Electronic module
- 7 Terminal module
- 8 Locking lever electronic module
- 9 Terminal

Status indication

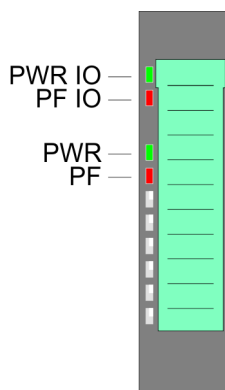

LED	Color	Description	
PWR IO	green	●	Power section supply OK
PF IO	red	●	Fuse power section supply defective (Power fail)
PWR	green	●	Electronic section supply OK
PF	red	●	Fuse electronic section supply defective

on: ● | off: ○ | blinks with 2Hz: B

Pin assignment

For wires with a cross section of 0.08mm² up to 1.5mm².

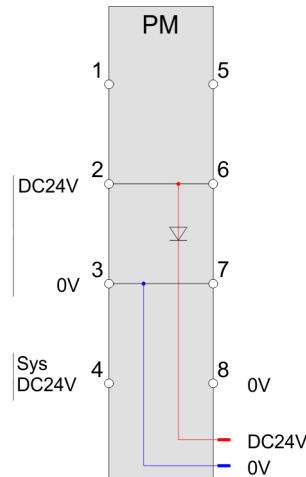
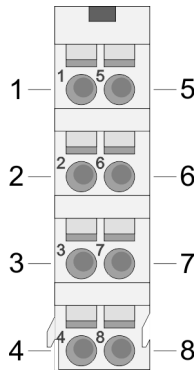

Pos.	Function	Type	Description
1	---	---	not connected
2	DC 24V	I	Feed-in DC 24V power section supply
3	0V	I	Feed-in ground GND power section supply
4	Sys DC 24V	I	Feed-in DC 24V electronic power supply
5	---	---	not connected
6	DC 24V	O	DC 24V power section supply I/Os
7	0V	O	ground GND power section supply I/Os
8	0V	I	Feed-in ground GND electronic power supply

I: Input, O: Output



- Power section and electronic power section supply are internally protected against higher voltage by fuses. The fuses are within the power module. If one fuse released, its electronic module must be exchanged!
- It is recommended to externally protect the power section supply with a fast 4A fuse respectively by a line circuit breaker 4A characteristics Z and the electronic power supply with a fast 1A fuse respectively by a line circuit breaker 1A characteristics Z.
- Please consider this module has no internal buffer concerning power dips. To match to the standard EN 61131-2, a power supply unit should be used, which can avoid power dips of up to 10ms.

WARNING!
 Please consider within wiring the maximum load current of the contacts. With the System SLIO this is max. 10A.

Deployment

The following figure shows the standard cabling of the power supply by means of a bus coupler.

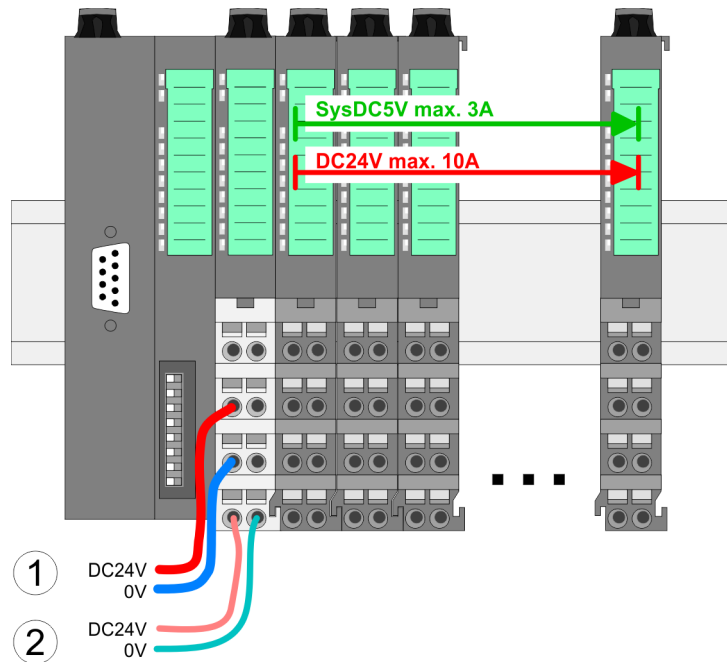

- 1 DC 24V for power section supply I/O area
- 2 DC 24V for electronic power supply bus coupler and I/O area

Expansion by the power module 007-1AB10

With a sum current greater than 3A the LEDs may not be activated. When the power module 007-1AB10 is placed, further modules may be placed besides the power module at the backplane bus, whose sum current of electronic power supply does not exceed 2A. On this way the System SLIO may be expanded up to a maximum of 64 modules. Additionally the power module serves for a new isolated group for the DC 24V power section supply with max. 4A.

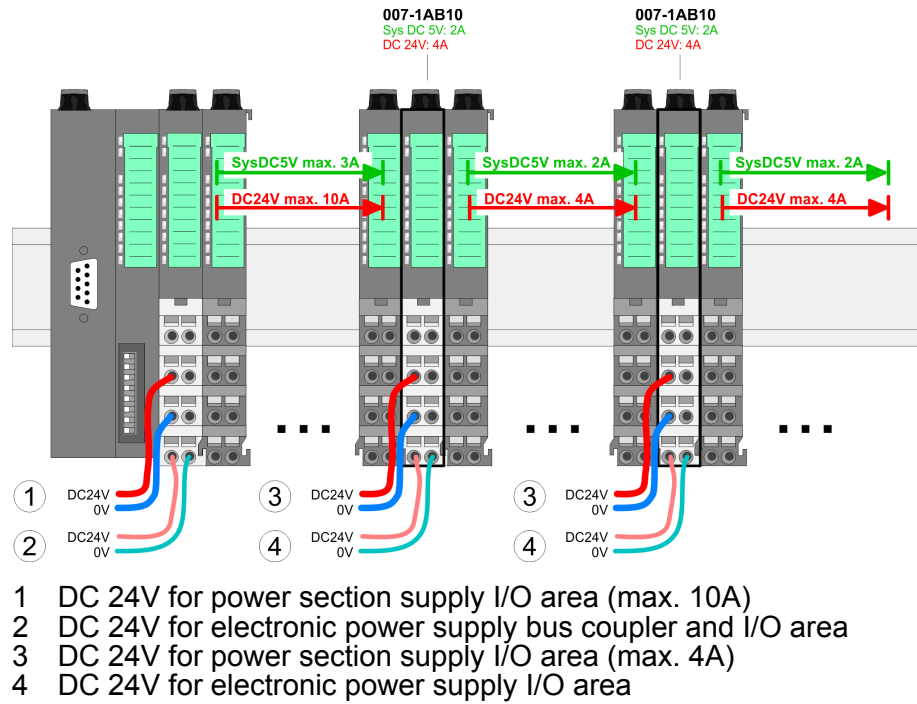

3.3.1 Technical data

Order no.	007-1AB10
Type	PM 007
Module ID	-
Technical data power supply	
Input voltage (rated value)	DC 24 V
Input voltage (permitted range)	DC 20.4...28.8 V
Mains frequency (rated value)	-
Mains frequency (permitted range)	-
Input current (at 120 V)	-
Input current (at 230 V)	-
Inrush current	-
Power consumption	-
Output voltage (rated value)	24 V
Output current (rated value)	4 A
Power supply parallel switchable	-
Reverse polarity protection	yes
Overvoltage protection	36 V
Ripple of output voltage (max.)	-
Efficiency	89 %
Power loss	1.4 W

Order no.	007-1AB10
Status information, alarms, diagnostics	
Status display	yes
Interrupts	no
Process alarm	no
Diagnostic interrupt	no
Diagnostic functions	no
Diagnostics information read-out	none
Supply voltage display	green LED
Group error display	red LED
Channel error display	none
Housing	
Material	PPE / PPE GF10
Mounting	Profile rail 35 mm
Mechanical data	
Dimensions (WxHxD)	12.9 mm x 109 mm x 76.5 mm
Weight	75 g
Environmental conditions	
Operating temperature	0 °C to 60 °C
Storage temperature	-25 °C to 70 °C
Certifications	
UL508 certification	yes

Derating diagrams electronic power supply

Convection

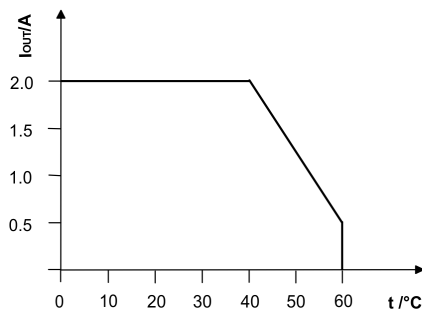

Air circulation 0.5m/s

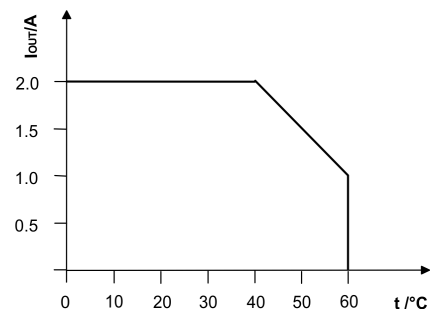

4 Clamp modules

4.1 001-1BA00 - 8xDC 24V clamps

Properties

This clamp module is a "potential distributor module". The DC 24V of the power section supply may be accessed by 8 clamp connectors of the terminal. The backplane bus is looped through the module. So this module has no module ID, but influences the maximum number of modules to be connected.

- 8 clamp connectors DC 24V power section supply
- Clamp current max. 10A
- Backplane bus looped through
- Isolation 500Veff (field voltage to the bus)

Structure

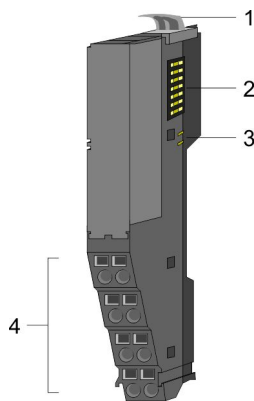

- 1 Locking lever terminal module
- 2 Backplane bus
- 3 DC 24V power section supply
- 4 Terminal

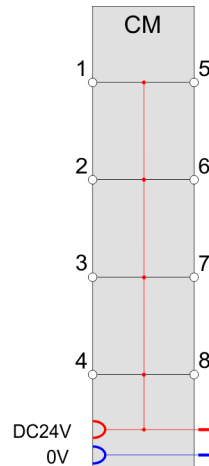
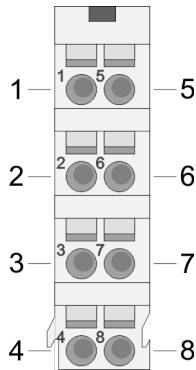
Pin assignmentFor wires with a cross section of 0.08mm² up to 1.5mm².

Pos.	Function	Type	Description
1	DC 24V	O	DC 24V power section supply
2	DC 24V	O	DC 24V power section supply
3	DC 24V	O	DC 24V power section supply
4	DC 24V	O	DC 24V power section supply
5	DC 24V	O	DC 24V power section supply
6	DC 24V	O	DC 24V power section supply
7	DC 24V	O	DC 24V power section supply
8	DC 24V	O	DC 24V power section supply

O: Output

4.1.1 Technical data

Order no.	001-1BA00
Type	CM 001
Module ID	-
Clamp parameter	
Terminal voltage max.	DC 30 V
Terminal current max.	10 A
Total current per module, max.	10 A
Isolated group	
Number of clamps	2*4
Binding of potential	Field voltage DC 24V
Potential group current, max.	10 A
Housing	
Material	PPE / PPE GF10

Order no.	001-1BA00
Mounting	Profile rail 35 mm
Mechanical data	
Dimensions (WxHxD)	12.9 x 109 x 52.5 mm
Weight	50 g
Environmental conditions	
Operating temperature	0 °C to 60 °C
Storage temperature	-25 °C to 70 °C
Certifications	
UL508 certification	yes

4.2 001-1BA10 - 8xDC 0V clamps

Properties

This clamp module is a "potential distributor module". The ground GND of the DC 24V power section supply may be accessed by 8 clamp connectors of the terminal. The backplane bus is looped through the module. So this module has no module ID, but influences the maximum number of modules to be connected.

- 8 clamp connectors ground GND power section supply
- Clamp current max. 10A
- Backplane bus looped through
- Isolation 500Veff (field voltage to the bus)

Structure

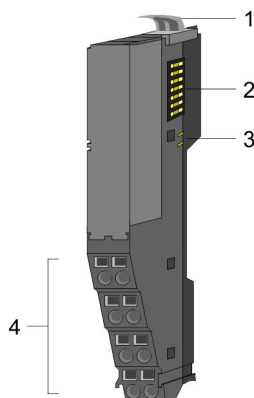

- 1 Locking lever terminal module
- 2 Backplane bus
- 3 DC 24V power section supply
- 4 Terminal

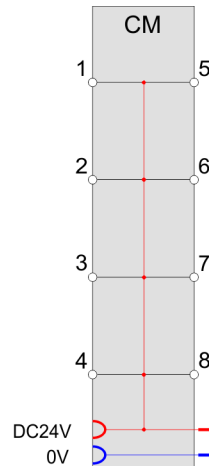
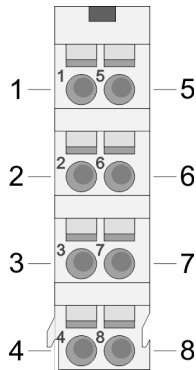
Pin assignmentFor wires with a cross section of 0.08mm² up to 1.5mm².

Pos.	Function	Type	Description
1	DC 0V	O	Ground GND power section supply
2	DC 0V	O	Ground GND power section supply
3	DC 0V	O	Ground GND power section supply
4	DC 0V	O	Ground GND power section supply
5	DC 0V	O	Ground GND power section supply
6	DC 0V	O	Ground GND power section supply
7	DC 0V	O	Ground GND power section supply
8	DC 0V	O	Ground GND power section supply

O: Output

4.2.1 Technical data

Order no.	001-1BA10
Type	CM 001
Module ID	-
Clamp parameter	
Terminal voltage max.	DC 0 V
Terminal current max.	10 A
Total current per module, max.	10 A
Isolated group	
Number of clamps	2*4
Binding of potential	Field voltage DC 0V
Potential group current, max.	10 A
Housing	
Material	PPE / PPE GF10

Order no.	001-1BA10
Mounting	Profile rail 35 mm
Mechanical data	
Dimensions (WxHxD)	12.9 x 109 x 52.5 mm
Weight	50 g
Environmental conditions	
Operating temperature	0 °C to 60 °C
Storage temperature	-25 °C to 70 °C
Certifications	
UL508 certification	yes

4.3 001-1BA20 - 4xDC 24V and 4xDC 0V clamps

Properties

This clamp module is a "potential distributor module". The DC 24V respectively ground GND of the power section supply may be accessed by 4 clamp connectors each of the terminal. The backplane bus is looped through the module. So this module has no module ID, but influences the maximum number of modules to be connected.

- 4 clamp connectors DC 24V power section supply
- 4 clamp connectors ground GND power section supply.
- Clamp current max. 10A
- Backplane bus looped through
- Isolation 500Veff (field voltage to the bus)

Structure

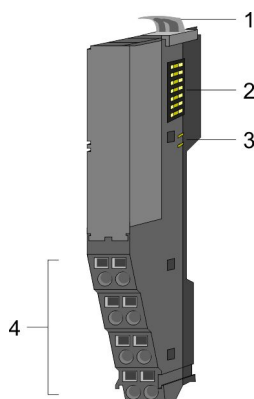

- 1 Locking lever terminal module
- 2 Backplane bus
- 3 DC 24V power section supply
- 4 Terminal

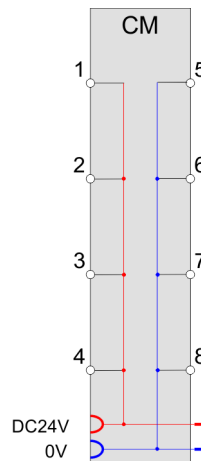
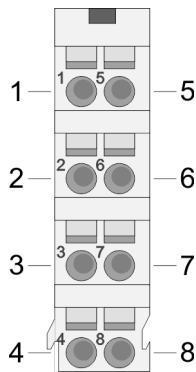
Pin assignmentFor wires with a cross section of 0.08mm² up to 1.5mm².

Pos.	Function	Type	Description
1	DC 24V	O	DC 24V power section supply
2	DC 24V	O	DC 24V power section supply
3	DC 24V	O	DC 24V power section supply
4	DC 24V	O	DC 24V power section supply
5	DC 0V	O	Ground GND power section supply
6	DC 0V	O	Ground GND power section supply
7	DC 0V	O	Ground GND power section supply
8	DC 0V	O	Ground GND power section supply

O: Output

4.3.1 Technical data

Order no.	001-1BA20
Type	CM 001
Module ID	-
Clamp parameter	
Terminal voltage max.	DC 30 V
Terminal current max.	10 A
Total current per module, max.	10 A
Isolated group	
Number of clamps	4
Binding of potential	Field voltage DC 24V
Potential group current, max.	10 A
Isolated group	
Number of clamps	4

Order no.	001-1BA20
Binding of potential	Field voltage DC 0V
Potential group current, max.	10 A
Housing	
Material	PPE / PPE GF10
Mounting	Profile rail 35 mm
Mechanical data	
Dimensions (WxHxD)	12.9 x 109 x 52.5 mm
Weight	50 g
Environmental conditions	
Operating temperature	0 °C to 60 °C
Storage temperature	-25 °C to 70 °C
Certifications	
UL508 certification	yes